

Cordless security: the ultimate customer experience.



The POD Series 3000 showcases InVue innovation at its best. Series 3000 is the first cordless security device for handheld electronics, allowing your customers the ultimate merchandise experience within a preset perimeter inside the store.

The new Series 3000 provides retail merchandise security with absolutely no cords, giving your customers unprecedented freedom in their shopping experience.



FEATURES AND BENEFITS

- 1 Completely cordless alarming security
- 2 Contact charging supports all Micro USB and Apple devices
- 3 “Gold is Good” LED indicates armed status
- 4 Alarm on product ensures that a stolen device can be tracked as it moves through or exits the store
- 5 Alarm in base ensures that alarm is heard, even if thief attempts to suppress alarm on product
- 6 Utilizes InVue IR Key to set perimeter and arm/disarm; part of the InVue IR Ecosystem™
 - › Fully adjustable security perimeter
 - › Pre-alarm warns customers when they are approaching security perimeter

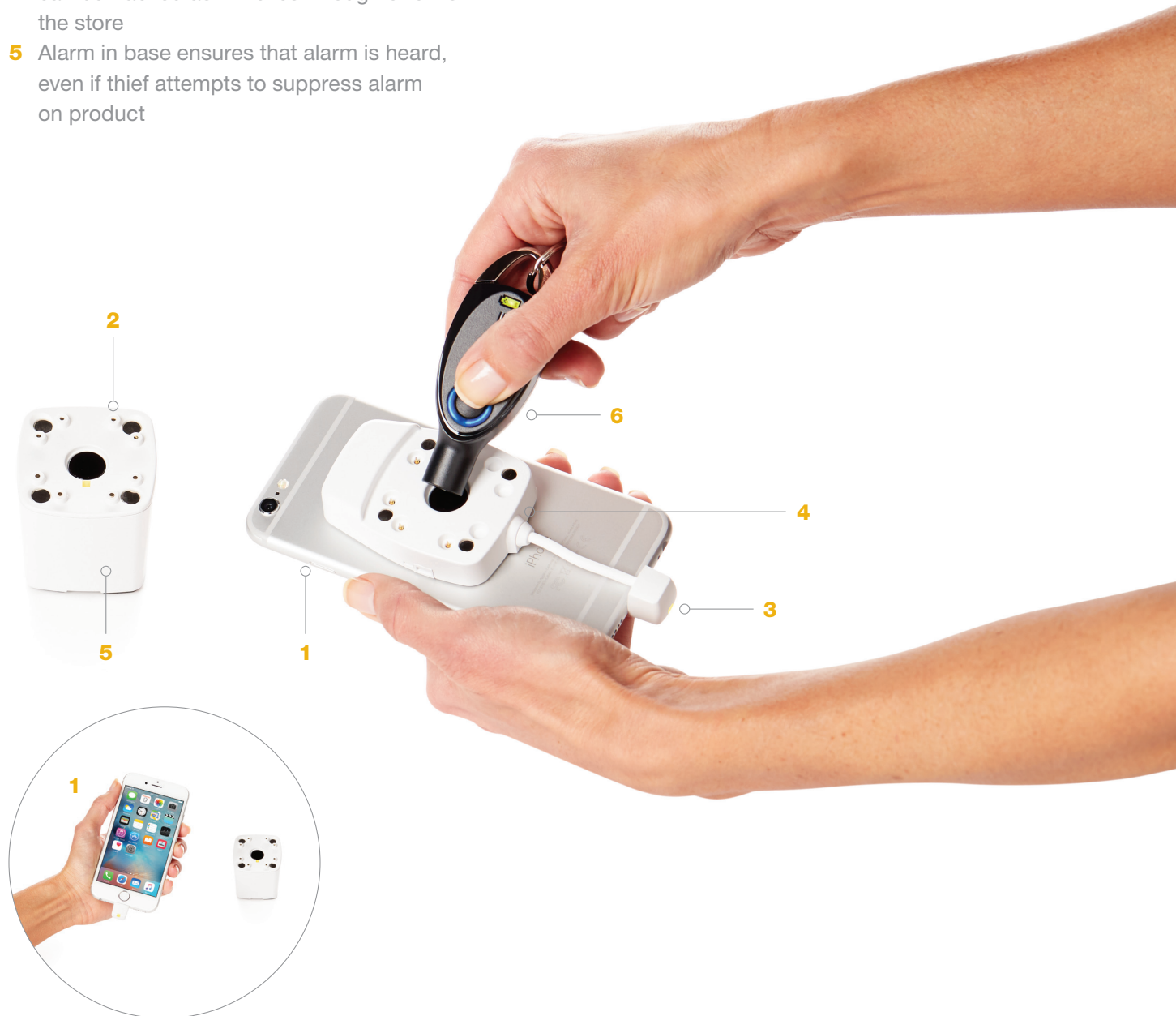

IR ECOSYSTEM™

Series 3000 is part of the exclusive InVue IR Ecosystem™, a storewide single key solution that improves customer service, increases sales and provides high theft protection.



Handheld Electronics

Electronic Accessories

Secure Fixtures

Package Protection

Locked Cabinets

Commercial Solutions



Series 3000

SPECIFICATIONS

Series 3000 Base (DWD100-W):

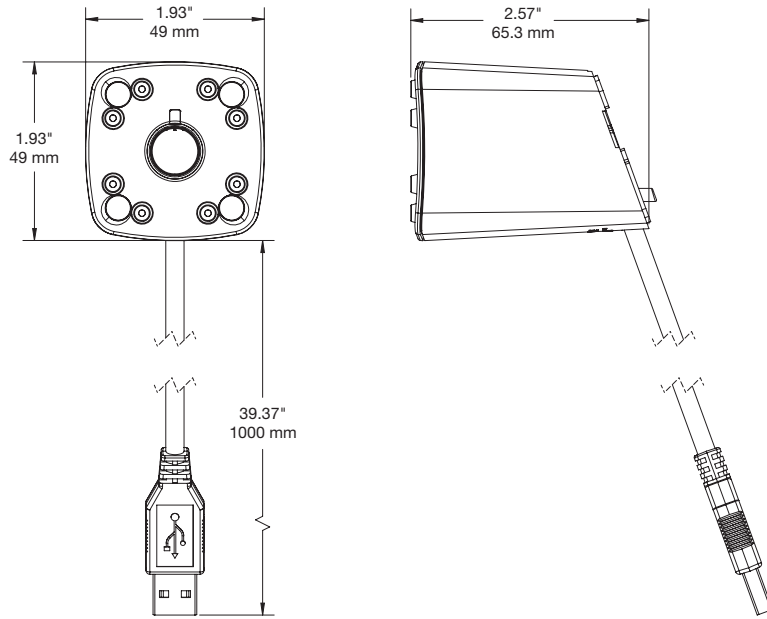

Series 3000 Handheld Sensor Micro USB (DWH200-W):

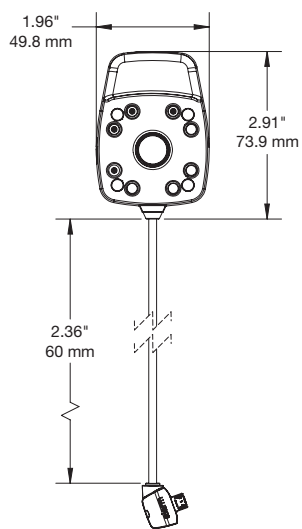

Series 3000

SPECIFICATIONS

Series 3000 Tablet Sensor Micro USB (DWT200-W):

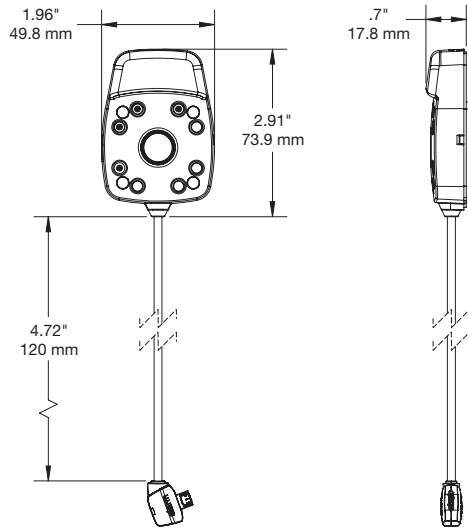

Series 3000 Handheld Sensor Apple Lightning (DWH203-W):

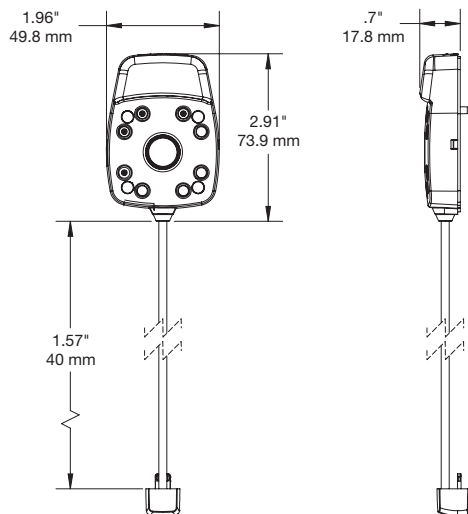

Series 3000

SPECIFICATIONS

Series 3000 Tablet Sensor Apple Lightning (DWT203-W):

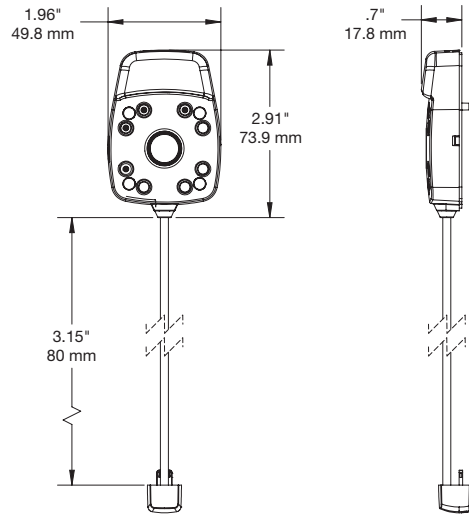

Series 3000

PRODUCT ORDERING

ORDER CODE	DESCRIPTION	CARTON QTY.
DWD100-W	Series 3000 Base - Gold LED	32
DWH200-W	Series 3000 Handheld Sensor Micro USB - Gold LED	32
DWT200-W	Series 3000 Tablet Sensor Micro USB - Gold LED	32
DWH203-W	Series 3000 Handheld Sensor Apple Lightning - Gold LED	32
DWT203-W	Series 3000 Tablet Sensor Apple Lightning - Gold LED	32
ADH2068	Series 3000 Stand Adhesive, 8 Pack	20
ADH2069	Series 3000 Sensor Adhesive, 8 Pack	20
PS515-US	5V Power Supply USB-A - US	32
PS515-UK	5V Power Supply USB-A - UK	
PS515-EU	5V Power Supply USB-A - EU	
PS515-AUS	5V Power Supply USB-A - AUS	

©2016 InVue Security Products. No endorsement of InVue products has been made by any of the manufacturers of the products shown. Product is sold pursuant to InVue's warranty which can be found at www.invue.com/warranty.

THE AMERICAS 704.752.6513 • 888.55.INVUE

EUROPE, MIDDLE EAST & AFRICA +31.23.8900150

ASIA PACIFIC +852.3127.6811



invue.com

